

hts.



Instructions for use.

hts. The universal hygiene system.

Our promise.



Dear Customer,

at this point we would like to thank you for placing your trust in our company and for purchasing our product. We ask you to read through the Instructions for use carefully prior to initial commissioning of the product, and to observe them. Please note that guidelines and representations in these Instructions for use may deviate from your product due to differing equipment.

We reserve the right to make technical modifications.

Important information!

Ensure that these Instructions for use remain with the product..

Your **schuchmann**-Team



1. Preparation.	05
1.1 Transport	05
1.2 Safety measures prior to use	05
1.3 Safe disposal	05
1.3.1 Packaging	05
1.3.2 Product	05
1.4 Where to keep the instructions for use	05
2. Product description.	06
2.1 General information	06
2.2 Handling / transport	06
2.3 Application areas, use according to the intended purpose	06
2.3.1 Indikationen / Kontraindikationen	07
2.4 Use not in accordance with the intended purpose / warning guidelines	07
2.5 Equipment for basic model	08
2.6 List of accessories	08
2.7 Product overview	09
3. Settings.	09
3.1 Back angle adjustment	10
3.2 Armrest adjustment	10
3.3 Seat depth adjustment	10
4. Accessories.	11
4.1 Subframes	11
4.1.1 Transfer and care subframe	11
4.1.2 Mobile & rigid subframe	12
4.1.3 Bath subframe	12
4.1.4 Travel subframe	13
4.2 Pads	13
4.3 Headrest	14
4.4 Thorax pelotte pads	14
4.5 Pelvic harness	15
4.6 Chest strap	15
4.7 Chest-shoulder strap	16
4.8 Thigh guides	17
4.9 Foot bench	17
4.9.1 Assembly on the toilet seat	18
4.9.2 Foot bench height adjustment	19
4.9.3 Foot bench angle setting	19
4.10 Calf guide	19
4.11 Ankle cuffs	20
4.12 Table/armrest	20
4.13 Attachment bar	21
4.14 Laufrollen	21
4.15 Abduction wedge	22

4.16 Deflector.....	22
4.17 Toilet bucket	22
4.18 Push handles.....	23
5. Repairs and cleaning.	23
5.1 Care.....	23
5.2 Repairs	23
5.3 Spare parts.....	24
5.4 Duration of use and re-use.....	24
6. Technical data.	24
7. Guarantee.	26
8. Identification.	27
8.1 EC declaration of conformity.....	27
8.2 Serial number / date of manufacture	28
8.3 Product version.....	28
8.4 Issue of the document.....	28
8.5 Name and address of the manufacturer, specialist dealer supplying the product.....	28

1. Preparation.

1.1 Transport

On receiving the product, please check it for completeness, lack of faults and check it for any transport damage. Inspect the goods in the presence of your forwarder. Should transport damage have occurred, please cause an inventory (determination of the faults) to be made in the presence of the forwarder. Please send a complaint in writing to the specialist dealer responsible.

1.2 Safety measures prior to use

Correct usage of the hygiene system requires precise and careful induction of the accompanying person. We ask you to read through the instructions for use carefully prior to initial commissioning of the toilet and shower chair, and to observe them.

1.3 Safe disposal

In order to preserve and protect the environment, to prevent environmental pollution, and to improve the recycling of raw materials, please note the disposal instructions in **points 1.3.1** and **1.3.2**.

1.3.1 Packaging

The product packaging should be stored in case the product needs to be transported again. Should you have to return the product for repairs or in case of a guarantee claim, please if possible use the original box so that the product is optimally packaged. Separate the packaging materials for recycling according to their classification. Do not leave packaging materials unattended, as they are a possible source of danger.

1.3.2 Product

Separate the raw materials used in the product for recycling according to their classification (see material information under **2.1**)

1.4 Where to keep the instructions for use

Please store these instructions for use carefully and ensure that these Instructions for use remain with the product in case of re-use.



2. Product description.

2.1 General information

All individual steel parts (nuts, bolts and screws etc.) are made of stainless steel. The padded parts are made of waterproof polyurethane integral foam. The frame is made of aluminium and stainless steel and is powder-coated. The straps are made of polypropylene fibres with quick drying mixed spacer fibres for the padding. The plastic parts are injection moulded from various synthetic resins. All materials are free of latex, lead and phthalates.

2.2 Handling / transport

The hygiene system is not designed to be carried. If you have selected a mobile subframe, **hts.** is equipped with castors. Should you have to carry the equipment due to obstacles, ensure that all moving parts are tightened. Then position yourself next to the hygiene system, grip it on both sides under the support head and carry it to the required location. To transport the hygiene system, reduce all adjustments to their most compact size (fold up foot bench, set lowest seat height etc.)



Tighten all moving parts prior to carrying!

2.3 Application areas, use according to the intended purpose

As a toilet chair, **hts.** can be used with the toilet or as a standalone device with a toilet bucket. It can also be used as a toilet seat on the toilet, as a shower chair and shower seat. Please observe the following guidelines:

Over the toilet

With the moving subframe, **hts.** can easily be pushed over the toilet. The height setting allows it to be adjusted to fit the existing toilet.

On the toilet

Rifton **hts.** can be used as a toilet seat on the toilet with the help of an attachment bar.

Standalone toilet chair/shower chair

The **hts.** seat unit can be used as a standalone toilet chair/shower chair in combination with a subframe (see **4.1**).

As a shower chair

The **hts.** seat unit can be used as a shower chair in combination with the bath subframe.

2. Product description.

2.3.1 Indications / contraindications

Indications for use as a toilet seat adapter

Disease symptoms such as flaccid or spastic paralyses as a result of child cerebral palsy, muscular dystrophy or other diseases resulting in similar disabilities which cause a combination of insufficient torso control with functional disorders or the lower extremities and for which conventional children's toilet seats are insufficient.

Indications for use as a toilet stool:

Physically and/or mentally disabled children or children with dwarfism who are not able to use either conventional children's toilet seats or WC bowls.

Contraindications

In general, the indications for provision of a toilet adapter or bowl should be approved by a doctor or orthopaedist. It should therefore be clarified prior to procurement whether contraindications exist for the patient. In general, any type of pain represents a contraindication.



2.4 Use not in accordance with the intended purpose / warning guidelines

- Correct usage of the product requires precise and careful training of the accompanying person.
- The hygiene system may only be used on stable and flat ground.
- Please observe the „Technical data“ in these instructions for use for the maximum permitted patient weight.
- The hygiene system may not be used without supervision.
- The hygiene system may not be used to transport people.
- During adjustment, the user should not be able to touch the moving parts.
- Only use accessories and spare parts made by Schuchmann, otherwise you will endanger the child.
- Only use the hygiene system if all components have been correctly mounted and adjusted.
- Please read out the Instructions for use for users suffering from a visual or reading impairment, so that they can use the subframe safely.



2. Product description.

2.5 Equipment for basic model

- Seat unit incl. pelvis harness and removable armrests
- Adjustable seat depth and back angle

2.6 List of accessories

- Mobile subframes
- Rigid subframes
- Transfer- and care subframe
- Bath subframe
- Pads
- Headrest
- Thorax pelotte pads
- Chest strap/chest-shoulder strap
- Thigh/calf guide
- Table/armrest
- Deflector
- Abduction wedge
- Toilet bucket
- Foot bench
- Ankle cuffs
- Attachment bar
- Calf guide
- Travel subframe
- Push handles

2. Product description.

2.7 Product overview

The Fig. below is intended to show you the designation of the most important components as well as the terms which you will find in these Instructions for use.

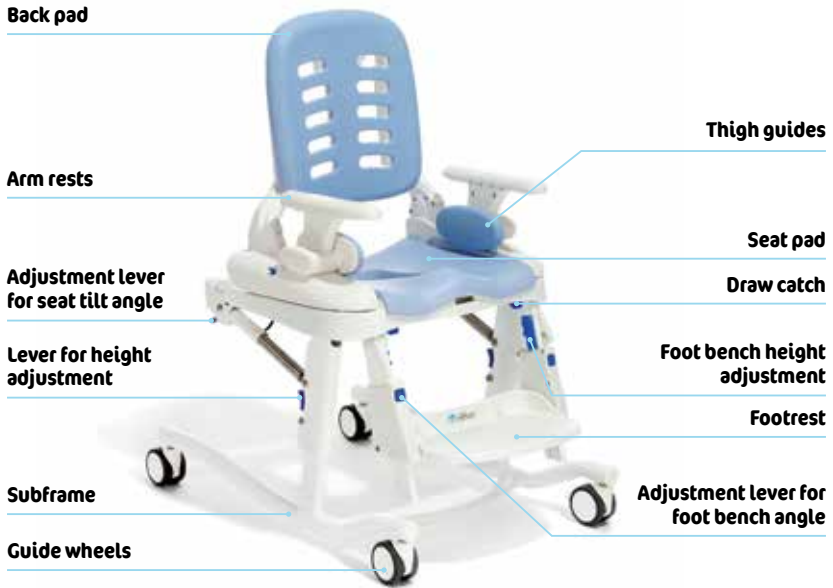

3. Settings.

Settings and adjustments to the product or accessories may only be made by people who have been given the necessary instructions by a medical product advisor. Please ensure that none of the user's extremities are in the respective area when making adjustments of any kind to minimise the risk of injury.



3. Settings.

3.1 Back angle adjustment

The back angle can be adjusted 6° to the front (A), 6° to the back (B), and 18° to the back (C). To set the back angle, pull both sides of the back up, bring it into the required position and leave go of the levers. Make sure that the back audibly clicks into place.



Assembly/disassembly of the back:

To disassemble the back, remove the arm rests (E - see 3.2) and the thigh guides (if available, see 4.8) beforehand. Press the lever (D) and then tilt the back all the way forwards until the F and G markings are on top of each other. Now you can take the entire back out of the mount. To assemble the back, simply place it back in the mount so that the F + G markings are on top of each other again. Then pull the back towards the rear until it clicks into the first setting.

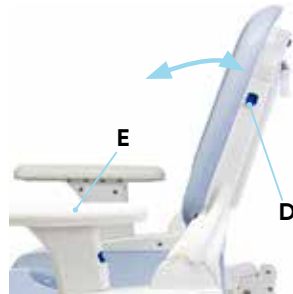

Only assemble/disassemble the back when not in use!

3.2 Armrest adjustment

In order to attach the armrest (A), insert the lower side of the armrest into the oval opening (B) in the seat unit and push it down firmly until it clicks into place. To remove the armrest, press the release button (C) and pull the armrest up.

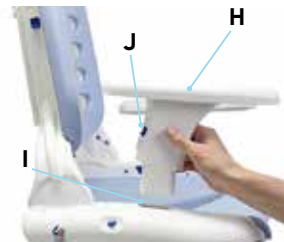

3.3 Seat depth adjustment

You can adjust the seat depth on the seat unit. To do so, pull the blue draw catches (D) up on both outer sides, set the required seat depth and make sure that the seat clicks into place. The side parts of the seat unit can be fully taken off to the front in this way so that the surface below can be cleaned.



4. Accessories.

4.1 Subframes

Two mobile subframes, two rigid subframes, a bath subframe and a travel subframe are available as options.

In order to attach the seat onto a subframe, place both hooks (A) on the back of the seat unit into the brackets (B) of the respective subframe. Then press the front of the seat onto the frame with applying a little force until the draw catches (C) audibly click into place.

In order to take the seat unit out of the frame, pull both draw catches (C) under the front corner of the seat and lift it from the front out of the frame while bending over the seat.



Make sure that both seat hooks are inserted in the brackets (B) on the subframe and that both draw catches (C) audibly click into place in order to avoid injuries!

4.1.1 Transfer and care subframe

The transfer and care sub-frame can be adjusted in height. In order to adjust the height of the transfer and care sub-frame, press down the foot pedal (D) on the left or right-hand side of the sub-frame with your foot until the subframe is in the required position.

In order to lower the sub-frame, lift up the foot pedal (D) from below using your foot. To adjust the tilt, press the adjustment lever (E) on the right, rear side of the seat to release the two gas pressure springs. The seat can be tilted 5 ° to the front and 25 ° to the back. The **hts.** can also easily be tilted with the user seated in the unit by applying a little force. For the adjustment of the foot bench permanently mounted on the sub-frame, see **points 4.9.2 and 4.9.3.**



4. Accessories.

4.1.2 Mobile & rigid subframe

The mobile and the rigid subframes can be adjusted in height. In order to lower the seat, press both levers for the height adjustment (**A**) on the lengthways struts on the frame, while supporting the weight of the seat. Lower both sides evenly so that the seat does not block.

Fold the foot bench up (see 4.9) to put the seat up, place one foot on the subframe (**B**) of the frame and lift up the seat frame (the lever for height adjustment must not be released).

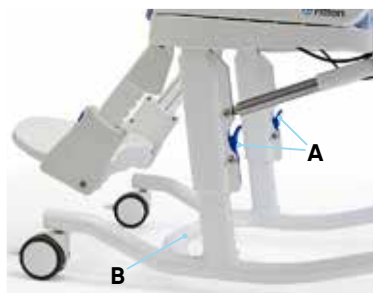

The height may only be adjusted when not in use!

It is possible to set the seat tilt on the mobile subframe. Press the adjustment lever (**C**) on the right, rear side of the seat to release the two gas pressure springs. The seat can be tilted 15 ° to the front and 15 ° to the back or 5° to the front and 25° to the back. **hts.** can be easily tilted with the user seated in the unit by applying a little force.

In order to apply the brake, press the brake lever (**D**) downwards. Put the lever back up to release the brake.

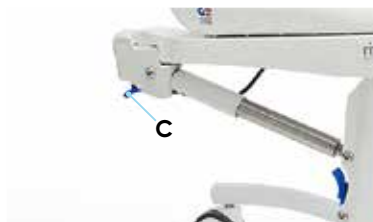

4.1.3 Bath subframe

The bath frame is for use in a bath in order to allow the user to bathe or shower (see 4.1 for assembly of the seat unit on the subframe).



4. Accessories.

4.1.4 Travel subframe

The travel subframe is a light, folding frame with a matching bag (A). The frame fits in the rear compartment on the bag (B). The seat, backrest, armrests and other accessories can be stored in the front compartment of the bag (C).

In order to assemble the frame, fold both parts of the subframe apart and insert the square pipe on the other part into the square pipe on the other part of the subframe (D). Make sure that both parts of the frame click into each other properly before attaching the seat. Then fix the toilet seat onto the frame (see 4.1).



The travel subframe cannot be used for hts. size 3!

4.2 Pads

All pads can be removed for cleaning. Pull the press fasteners (E) out of the recesses (F) to remove. The pads are made of polyurethane with a durable integral foam. There are three different types of seat pad. One has a slighter larger opening and is open at the back (G) to facilitate hygienic care.

The opening on the second type is slightly smaller and closed at the back (H), so that the user is supported even better. The third one (I) is a no-hole seat pad. Each pad is attached with the press fasteners (E), which are pressed into the recesses (F) provided.

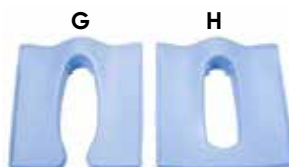

4. Accessories.

4.3 Headrest

In order to attach and set the headrest, press the button for height adjustment (A). Insert the headrest into the opening (B) provided and set the required height.

Now let go of the button (A) and set the required height until it audibly clicks into place. In order to adjust the depth and angle of the headrest, release the oval twist lever (C), set the headrest to the required position and tighten the lever again.

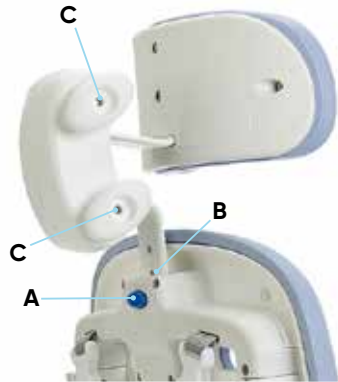

4.4 Thorax pelotte pads

The thorax pelotte pads are available with or without a chest strap and ensure that the upper body is securely positioned. They can be separately adjusted in height, angle and width with the twist lever (D) behind the backrest. In order to attach and/or set the thorax pelotte pads (E), loosen the twist lever (D) and attach them above the rail on the rear of the back. Set the height, angle and width of the thorax pelotte pads for the patient by pushing the pelottes up and down, moving the slot back and forth and by turning the clip (F) around the twist lever. Tighten the twist lever (D) once the required position has been reached. See 4.2 for removal of the pads.



4. Accessories.

4.5 Pelvic harness

Each **hts.** is equipped with a pelvic harness. In order to use the pelvic harness, insert the fixing clip into the opening on the back of the side piece. Make sure that the pelvic harness has clicked in well. It is possible for users who slide the seat a little to the front to guide the pelvic harness past the inner side of the supports on the backrest. In order to ensure that little, active users are securely seated, there is an additional option for attachment of the pelvic harness on **hts.** Size 1. Guide the strap through the hooks on the back of the seat area.

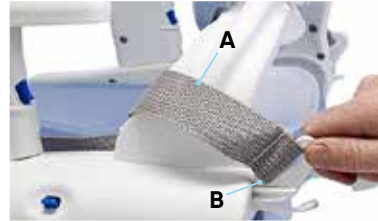

Always use the pelvic harness to avoid accidents.

4.6 Chest strap

The chest strap is attached to the thorax pelotte pads. The chest strap goes into the inner side of the thorax pelotte pads. Dismantle the thorax pelotte pads (see **4.4**) first of all, then insert the ends through the loop (A) and reattach the thorax pelotte pads.

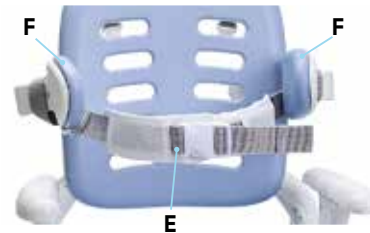

4. Accessories.

4.7 Chest-shoulder strap

The centre section on the pelvic harness (A) must be removed first to attach the chest-shoulder strap. For this, use the chest-shoulder strap (B) with the integrated pelvic harness. Tighten the pelvic harness and insert the shoulder straps into the brackets on the backrest. You can also pull the shoulder straps through the upper opening in the backrest for smaller users.

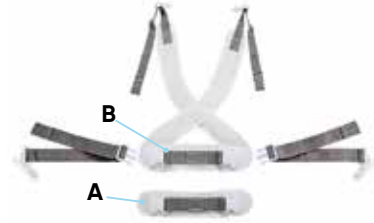

Tighten the pelvic harness on the chest-shoulder strap before tightening the upper straps. Check the fit of the strap after each setting.



4. Accessories.

4.8 Thigh guides

The seat width can be adapted with the thigh guides, which can be attached to the armrests. The seat width reduces by 5 cm in the first position and by 10 cm in the second position. Slide the thigh guides into the armrest so that the inlet (A) in the thigh guides point up and to the back. Insert the armrest (B) through the thigh guides into the recess for the armrest. See 4.2 for removal of the pads.

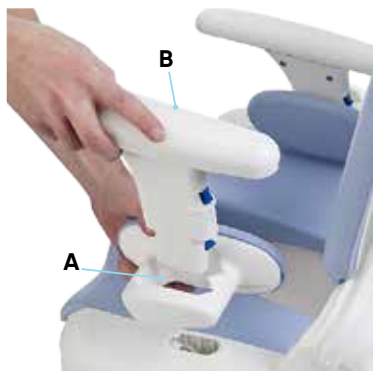

4.9 Foot bench

The foot bench can be assembled as an accessory on the toilet seat or is already fixed to the mobile subframe.



4. Accessories.

4.9.1 Assembly on the toilet seat

Please observe the following advice when attaching the foot bench onto the **hts.** seat unit.

1. Insert the little metal brackets (**A**) on the ends of the frame (**B**) into the recess (**C**) on the back of the seat unit.
2. Firmly press the foot bench down so that the frame audibly clicks into the blue brackets (**D**).
3. Fix the **hts.** seat unit onto the attachment bar (see **4.13**). The foot bench is included in the scope of supply for mobile subframes.

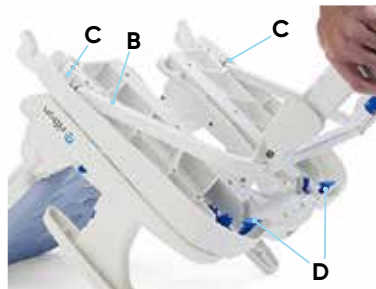
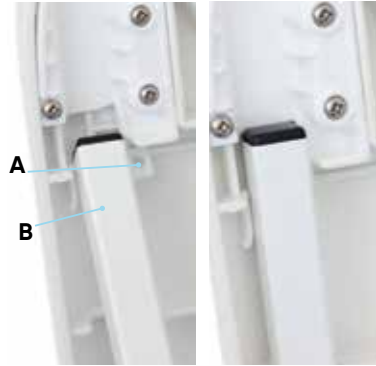

4. Accessories.

4.9.2 Foot bench height adjustment

In order to adjust the height of the foot bench, press both buttons for height adjustment (A), set the foot bench to the required height and allow the buttons to audibly click into the place in the required position.

4.9.3 Foot bench angle setting

The angle of the foot bench can be adapted by pushing both levers (B) up and setting the foot bench to one of the four angles. The foot bench can be also be folded in when transporting at ground level.



4.10 Calf guide

The calf guide (C) is fixed above the foot bench (D). It should be removed if the foot bench is set to one of the upper positions. The calf guide is attached to the long supports on the foot bench. With the strap pointing backwards and the rounded corners downwards, wind the strap around the long supports and push it through the metal ring from the front. Allow the hook to click into place and fix the strap so that it closes tightly around the long supports.



The calf guide option requires the use of a foot bench!



The load on the foot bench may not exceed 68 kg to avoid falls, tipping over and other injuries!



4. Accessories.

4.11 Ankle cuffs

Slide the loop on the strap through the horizontal opening on the back of the foot bench to attach the ankle cuffs. Turn the strap and push it into the vertical opening. Tighten it until it clicks into place. The straps with Velcro can be washed at 30 ° C. Seal the Velcro before washing. Do not iron.



This option requires the use of a foot bench.

4.12 Table/armrest

The table has a padded, large sized stomach contact area, on which the user can support him or herself (see **point 4.2** for removal of the pad). This offers a comfortable position, gently bent to the front, for using the shower and toilet. The upper body and arms are supported by the table. Pull the lever (**A**) under the table in order to adjust the depth of the table.

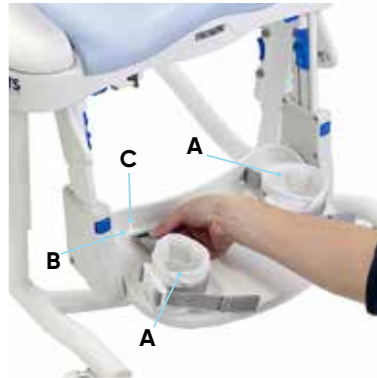

4. Accessories.

4.13 Attachment bar

There are two types of attachment bar for attachment on round standard toilets or on longer toilets. The attachment bar is fixed in place with the retainer screws used to attach the toilet lid and seat. They provide a secure fixing point for the seat and back units. In order to find out which type of attachment bar you need, measure from the centre axis of the retainer screws to the front edge of the WC bowl. If the distance is less than 43 cm, use the standard attachment bar (A), otherwise the long attachment bar (B). In order to attach the toilet seat onto the attachment bar, tilt or push the backrest forwards (see 3.1), then place both hooks (C) into the mount (D) on the attachment bar (see 4.1) and lower the seat onto the toilet bowl.



In order to prevent falls and injuries, make sure that the toilet is fixed securely to the ground and that the retainer screws are in a good condition before fixing the attachment bar. Check the stability of the toilet and retainer screws at regular intervals while using the attachment bar.

4.14 Castors

The mobile sub-frames and the care and transfer sub-frames are equipped with 4 castors. These should always be secured against unwanted rolling away. The castors have a total stop with directional locking devices which prevent unwanted rolled and twisting. To do this, press the locking devices (E) on each castor with the tip of your foot (F). To release the castors, push the locking devices back up again with the tip of your foot (G).

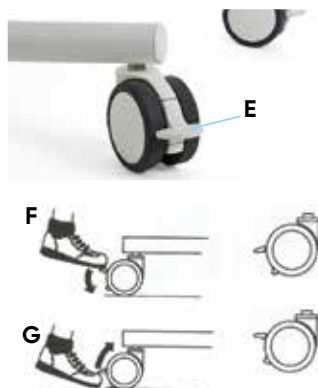

The brakes only work reliably on an even surface!



4. Accessories.

4.15 Abduction wedge

The padded abduction wedge is attached to the front edge of the toilet seat. Remove it again by pressing the blue lever (A) and pulling the abduction wedge out to the front. The hygiene system should be disinfected after each use with wipes or a solution with up to 10 % bleach. Apply some force to remove the pads (see 4.2) and clean with soapy water or a mild disinfectant.

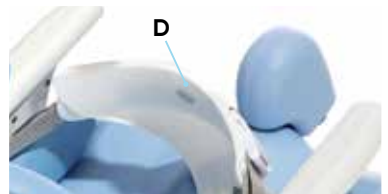
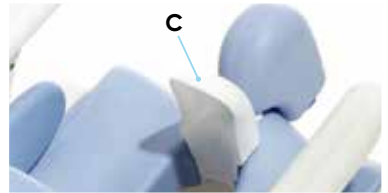
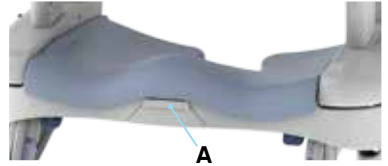

4.16 Deflector

The standard deflector (B) is inserted into the seat pad opening with the hollow side facing the user. The deflector with splash guard (C) ensures even better coverage. It is kept on the user with the pelvis harness or chest-shoulder strap. The use of the abduction wedge together with the deflector gives the deflector added stability.

4.17 Toilet bucket

With the toilet bucket, **hts.** can be used as a standalone toilet chair. Insert the bucket in the rails under the toilet seat from the back of the seat. Push it so far in until it clicks into place. Remove it again by pulling it out to the back.

E



F



4. Accessories.

4.18 Push handles

The push handles allow to slide the user more easily. The push handles are attached to the back unit from **hts.**. Slide the handgrips (**A**) into the recess (**B**) on the back unit and tighten the thumbscrews (**C**).

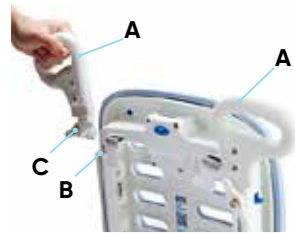

5. Repairs and cleaning.

5.1 Care

The hygiene system should be cleaned after each use with disinfectant wipes or a disinfectant solution with up to 10 % bleach. The straps with Velcro can be washed at 60 ° C. Seal the Velcro before washing. Do not iron. The pads made of polyurethane are easy to remove so that can be cleaned well and dry on the underside. They can be cleaned with soapy water or a mild disinfectant. The seat and the base are to be properly cleaned at 80° in a washing and disinfection system. Dissamble the chair as follows : separae the seating unit from the subframe , pick up the back part and remove the seat side part by pushing forward. Please also pay attention to our general cleaning and hygiene advice. You can find them at www.schuchmann.de/hts.



Do not use aggressive cleaning agents such as solvents, hard brushes etc.

5.2 Repairs

Please carry out a daily visual inspection and check the hygiene system regularly for cracks, breaks, missing parts and malfunctions. In case of a defect or malfunction, please contact the specialist dealer who supplied you with the product (see **point 8.5**).



5. Instandhalten und Reinigen.

5.3 Spare parts

Should you wish to order spare parts, please contact the specialist dealer who supplied you with the hygiene system, stating the serial number of the chassis (see **point 8.5**). Necessary spare parts and accessories must only be installed by trained personnel.

5.4 Duration of use and re-use

The expected duration of use of our product, dependent on the usage intensity and amount of re-use, totals up to „8“ years, if the usage takes place in accordance with the information in these instructions for use. It may be possible to use the product over and above this time period if it is in a safe condition. The expected duration of use does not refer to wear parts, such as for example covers, wheels, batteries.....

The maintenance and evaluation of the condition, and if applicable the potential for re-use must be decided by the specialist trader. The hygiene system is suitable for re-use. Please follow the cleaning and disinfection instructions in Chapter 5.1. Accompanying documents such as these instructions for use are part of the product, and must be transferred to the new user. No disassembly is required prior to re-use. In the case of storage, it is recommended to fold the product to the smallest dimension to save space.

6. Technical data.

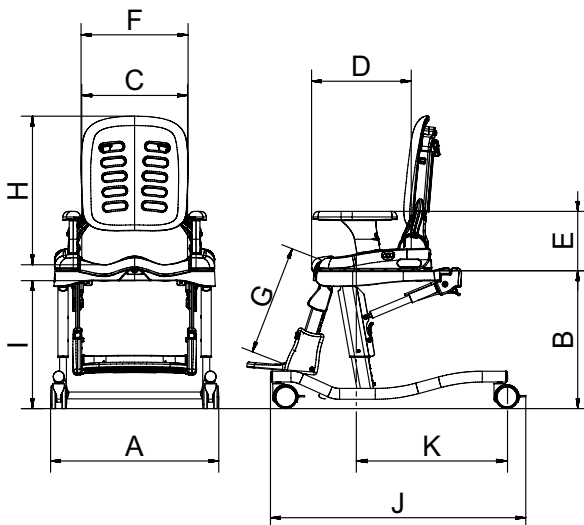

6. Technical data.

Dimensions - basic model

		Size 1	Size 2	Size 3
A	Total width	54 cm	54 cm	58,5 cm
	Seat height mobile subframes	41 - 58 cm	41 - 58 cm	41 - 58 cm
B	Seat height fixed subframes	31 - 43 cm	31 - 43 cm	38 - 48 cm
	Seat height transfer and care subframe	51 - 78 cm	51 - 78 cm	51 - 78 cm
C	Seat width	20* / 25* / 30 cm	25* / 30* / 36 cm	33* / 38* / 43 cm
D	Seat depth	20 / 23 / 25 / 28 cm	29 / 32 / 34 / 37 cm	37 / 40 / 42 / 44 cm
E	Armrest height	14,5 / 18 cm	18 / 22 cm	18 / 22 cm
F	Back width	29 cm	34 cm	41 cm
G	Lower leg length toilet seat	20 - 33 cm	25 - 38 cm	33 - 46 cm
H	Back height	42 cm	50 cm	62 cm
I	Max. position above toilet height	52 cm	52 cm	52 cm
J	Length of mobile subframes	74 cm	74 cm	80 cm
	Length of transfer and care subframe	84 cm	84 cm	87 cm
K	Front edge of the hygiene opening to the back edge of the mobile subframe	48,5 cm	48,5 cm	48,5 cm
	Front edge of hygiene opening to back edge of subframe	48 cm	48 cm	48 cm
	Back angle	(-)6°, 6°, 18°	(-)6°, 6°, 18°	(-)6°, 6°, 18°
	Seat angle	(-)5° - 25°	(-)5° - 25°	(-)5° - 25°
		(-)15° - 15°	(-)15° - 15°	(-)15° - 15°
	Max. load	34 kg	68 kg	113 kg
	Wide toilet seat	51,5 cm	51,5 cm	59,5 cm
	Max. traversable toilet width	41 cm	41 cm	46 cm
	Weight seat unit	5 kg	5 kg	8 kg

* adjustable with optional thigh guide



7. Guarantee.

The two-year statutory guarantee period shall apply for all products. This guarantee period shall begin with the delivery or handover of the goods. Should a verifiable material or manufacturing fault occur within this time period, we shall, after carriage paid return to us, view the indicated damage and, if applicable, either repair or deliver a new product at our discretion.

8. Identification.

8.1 EC declaration of conformity

Company Schuchmann GmbH & Co.KG
 Dütestr. 3
 D-49205 Hasbergen
 Tel.: +49 (0) 54 05 / 909 - 0
 Fax: +49 (0) 54 05 / 909 - 109



declares on their sole responsibility that the product named below is classified as product class 1

hts. The universal hygiene system

Art. No.: 57 0x xxx (Z1xx)

The relevant regulations of the regulations and guidelines listed below accord with:

- EC Directive 93/42/EEC on medical products from 14th June 1993
- DIN EN 12182 Technical aids for the disabled
- EN ISO 14971 Medical products – Application of risk management on medical products
- ISO 7176-8 Wheelchairs – Part 8: Requirements and tests on static strength, impact and fatigue strength

This declaration of conformity applies only for products with the article numbers stated above and is valid until 31.12.2019.

Date 26.02.2018

Signature

Name Torsten Schuchmann

Role Safety Representative for Medical Products



8. Identification.

8.2 Serial number / date of manufacture

The serial number, the date of manufacture and other information can be found on the type plate, which is located on all of our products (A).

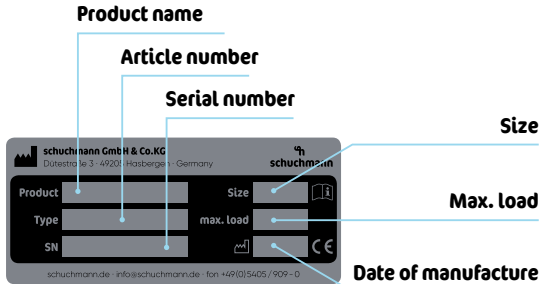

8.3 Product version

The **hts.** hygiene system is available in three sizes and can be supplemented through a diverse range of accessories (see **Point 4**).

8.4 Issue of the document

Instructions for use **hts.** – Change status J; Issue 09.2018

8.5 Name and address of the manufacturer, specialist dealer supplying the product

This product was manufactured by:



Schuchmann GmbH & Co. KG
 Dütestraße 3 · 49205 Hasbergen
 Tel. +49 (0)5405/909-0 · Fax +49 (0)5405/909-109
 info@schuchmann.de · www.schuchmann.de

This product has been delivered by the following specialist dealer: